

ANTIMICROBIAL PRODUCTS



MLR103X_ANMB

90° Flush Mount Side Wall Grab Rail LH in Antimicrobial

Specification

Material	#304 Stainless Steel - 32mmØ
Finish	Antimicrobial Coating
Mounting	Concealed Fix - 78mmØ Mount Stand-off 55mm
Specify	MLR103X_ANMB
Also Available	MLR103X_SS : Satin Stainless Steel MLR103X_DESIGNER : Designer Black
Note	<p>* This unit is accessible compliant when installed in accordance with AS1428.1. guidelines.</p> <p>* It is the responsibility of the installer to ensure that the surface/substrate that the unit is installed upon is suitable to withstand the weight bearing loads of the unit and if required as per AS1428 / Australian building code regulations.</p> <p>* Compliant with the Force Requirements within AS1428.1: 2021, Section 14.</p>

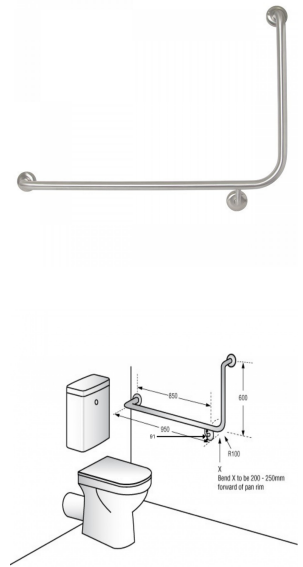

For installation instructions
download the Metlam Australia
App



Downloads & Resources

Care & Maintenance
 Installation instructions
 Associated Videos
 Stainless Steel Cleaning and Maintenance
 Metlam Australia's range of Antimicrobial
 How to install a Metlam Australia MLR103 Grab Rail

*The photographs and line drawings of the products presented above are representational only.
 Metlam Australia Pty Ltd reserves the right to, and from time to time, make changes and improvements in design and dimensions.*